



Vehicle Electronics



Contents

**Discover our
new products**



Your Vision. Our Technology.

We accompany you every step of the way – from the conception and development of a product to series production to after-sales service.

About MRS Electronic	4
Environmental & Quality Management	6
Product Portfolio	7
Controllers.....	8
Gateways	10
HMI-Systems	12
Relays	14
Programming Tools.....	16
Development Competencies	18
Production at our Headquarters	19
Markets	20
Applications	22
Hydraulic Control	22
Lighting Control	24
DC Motor Control	25
Sensor Processing	26
Trailer Control	28
Emission Monitoring.....	29
MRS Worldwide	30

About MRS Electronic

For more than 25 years, MRS has been developing and producing innovative electronic products, customer-specific hardware, and software solutions at its main location in Rottweil, Germany. With numerous international locations, including the USA, MRS supports customers worldwide.

1999

Management-Buy-Out and renaming into MRS Electronic

Around 20 Employees



since 2015

Internationalization of our businesses



2024

25 years anniversary of MRS Electronic



2006, 2011 & 2019

Increasing the company buildings by an amount of 5500 m²

2011
2019

2021

Over 250 employees in Rottweil

Environmental & Quality Management

Modern production technologies, open communication and continuous optimization of all business processes reflect our active concept of quality management.

Integrated management system & compliance



Quality

Our quality standards are geared to the expectations and wishes of our customers. We don't want to just meet the requirements, we want to exceed them. Quality runs like a red thread through the whole company and every single employee takes responsibility for the quality of his or her daily work.

Environment

We care about the environment, this is why we operate in a sustainable and environmentally conscious manner. We reduce and avoid waste, the use of hazardous substances and work in a resource-saving way. Our ambition is not only to comply with legal obligations, but to expand and exceed them. Therefore, our environmental management system has been certified according to the international standard DIN EN ISO 14001 since 2012.



Product Portfolio



Controllers



Gateways

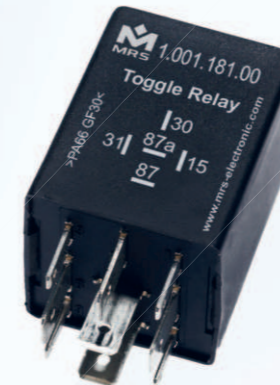

Relays



HMI-Systems



Connectivity

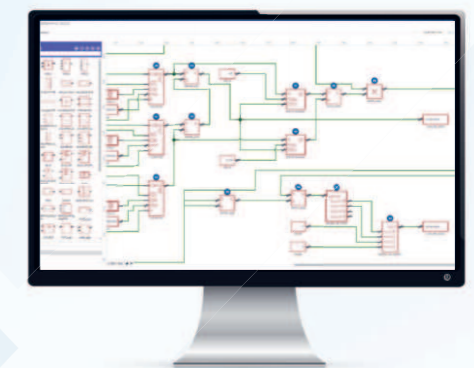

Software Tools

Controllers

Our compact electronic controllers generally operate digitally and have inputs, outputs, and interfaces. Use these components to control your vehicle, machines or systems. A programmable memory allows individual control instructions to be stored and executed via outputs.

Why MRS Controllers?



Flexibility of inputs and outputs

MRS controllers offer a high number of inputs and outputs. Thus, they are very flexible in use and can be connected to all common sensors, hydraulic valve types or DC motors on the market, among others.



Certifications up to IP6K8

Our waterproof and robust products with protection classes up to IP6K8 provide control mechanisms and reliable functionality even in extreme environmental conditions.

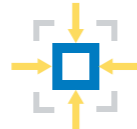

High functionality in the smallest installation spaces

Our compact products are particularly space-saving and still offer high flexibility. One of the smallest programmable controllers in the world, for example, is the MicroPlex®.

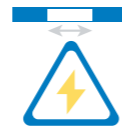

Wide operating voltage range

MRS controllers allow a wide variance in operating voltage. We have options of voltages between 9 and 32 volts.

CAN I/O – CC16WP – latest generation of CAN I/O



CAN I/O – CC16WP

The CAN I/O – CC16WP is the best CAN I/O generation from MRS Electronic. The core piece, the 32-bit processor, provides you with more processing power and thus faster computing cycle times. You also benefit from more powerful gateway functionality and complex programming options for your applications. Due to the enormously high flexibility of the multifunction inputs, the CAN I/O is ideally equipped for a wide variety of cross-sector applications.



Connected Controllers

The connected controllers of MRS Electronic are used to extend existing CAN controllers but can also be used as stand-alone PLC controllers. Optionally, they can also be equipped with an RS485 or RS232 interface. Programming is done with the MRS Applica Studio.



PLC-Controllers

Controllers (PLC) are digitally operating electronic systems, which in the simplest case work with four components (inputs, outputs, operating systems and interfaces). These four components can be used to control machines or systems, as the name implies. Programmable memory allows user-oriented control statements to be stored and executed via the inputs and outputs.



Motor Controllers

The motor controllers are microcontroller controlled modules for e.g. automotive applications. Free configurability and programmability allow the realization of various applications. They are very compact and can therefore be used in many ways.

Gateways

As a central point for all control units, our gateways provide high performance in the transmission of data and information. MRS gateways are used in a wide range of industries - from automotive to off-highway - where they can control, coordinate and communicate to all control units in the vehicle. The modules are characterized by error-free and secure communication.

Use cases

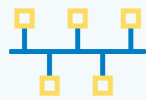

Changing bus topology

Connect or interconnect to an existing bus to add control functions.



Range extender

Message mirroring to compensate for voltage drop on long bus cables.



Changing the baud rate

Enable communication between bus nodes at different baud rates.



Editing bus messages

Changing objects within a bus message.



Message routing

Collecting bus messages and forwarding them to the correct bus.



Firewall

Filter bus messages with ID masks to select messages or reduce the computing load.

In focus: Changing bus systems

Gateways can be used to translate messages between sensors and a control unit. E.g. a LIN-based Rain-light-sensor and a CAN bus control system.

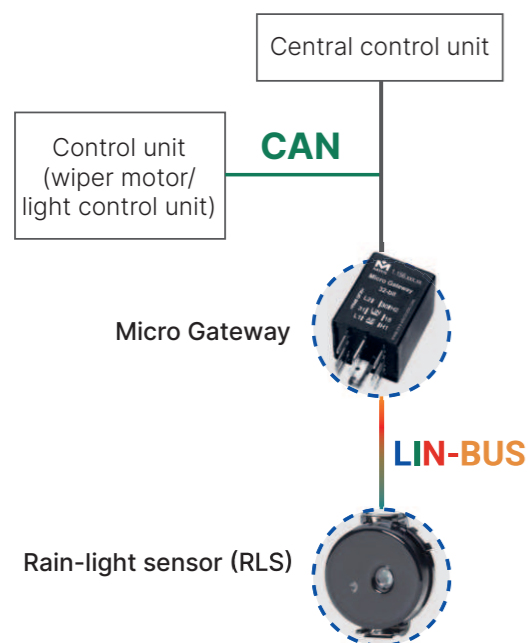

Is your machine secure yet?

In today's connected world, securing systems and networks is crucial, especially with stricter regulations like UNECE R 155. We provide secure solutions to protect your applications from unauthorized access and manipulation.



Optimal use for various applications

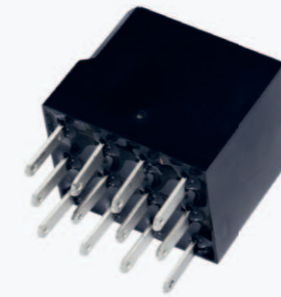

MicroPlex® Gateway 3CAN LIN

- ◆ 3x CAN interfaces (CAN FD capable)
- ◆ LIN interface optional
- ◆ 1x analog input
- ◆ 1x multifunctional input
- ◆ 8-32 V operating voltage



Micro Gateway

- ◆ 2x CAN interfaces (CAN FD capable)
- ◆ 2x LIN interfaces
- ◆ 2x analog inputs
- ◆ 2x pwm-capable outputs
- ◆ 9-32 V operating voltage



Universal Gateway 5x CAN

- ◆ 5x CAN interfaces
- ◆ LIN interface optional
- ◆ 1x analog input, 4x digital inputs
- ◆ 4x digital outputs
- ◆ 9-32 V operating voltage



Micro PLC CAN LIN

- ◆ CAN interface
- ◆ LIN interface
- ◆ 2x analog inputs
- ◆ 2x pwm-capable outputs
- ◆ 8-16 V operating voltage

HMI-Systems



MConn CAN Display

MConn is part of our HMI systems and features a quad-core processor with 2D, 3D, and vector graphics acceleration. Running on Embedded Linux, it supports Qt/QML programming and is fully customizable allowing customers to define I/Os, CAN interfaces, and wireless options, such as Wi-Fi and BLE. Thanks to the multi-touch PCAP touch screen, you can use functions such as pinch-to-zoom, rotation, flick and much more.

The standard variants include:

- ◆ 2x CAN interfaces and 1x LIN interface
- ◆ An Ethernet interface
- ◆ 22 I/O's
- ◆ A microphone input and audio outputs
- ◆ 4x analog camera inputs

Custom HMI development

Hardware customization



Define specification

Various specifications such as the number of I/Os, CAN interfaces, and Wi-Fi or BLE functionality.

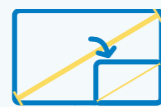

Choose screen size

The LCD screen size and shape can be adapted, ranging from 2 to 12.3 inches.



Optically or air-bonded screen

While air-bonded screens are more cost-effective, optically bonded screens offer higher display brightness.

Software customization



Linux operating system

Custom Linux distributions can be developed according to customer requirements.



Cloud connectivity

Cloud connectivity can be achieved in various ways, e.g. via Wi-Fi. Real-time data transfer is possible via protocols such as MQTT.



Board support package

If required we provide a complete Software package to the customer, allowing them to work on and maintain it independently.



TConn CAN Display

The TConn is a cost-efficient CAN display with an optically bonded display and a brightness of up to 850 candela/m² (nits).

The capacitive multi-touch screen comes in a size of 4.3- or 7-inch and keys with fluorescent print make operation particularly user-friendly.

Powered by an i.MX6 processor, the HMI system runs on a Linux operating system. Application programming is carried out using C++, Projektor or Qt/QML.

- ◆ Resolution of 480 × 272 pixels (TConn 4.3), 800 × 480 pixels (TConn 7)
- ◆ Deutsch DT plug

HMI application development

We offer platform agnostic development (iOS, windows, android). Therefore the HMI's application can be mirrored and also be used on an iPad or other external devices. The operator is not bound to the HMI in his vehicle. With this cross-platform development the same source code can be used like in the application for the Display.

Custom user interface (UI) design can be offered with designers that can create low and high fidelity designs.



Addressing outdated systems



Seamless migration to Qt



Strategic approach to migration



Relays

The electromechanical relays from MRS are flexibly parameterizable and offer the possibility to control a circuit with high voltages and currents with a small circuit. This allows a relay to be used, for example, as a protective relay for machines and devices, and then to switch off immediately in the case of incorrect operating values. In addition, MRS relays are very well suited to control time-delayed circuits of any kind.

Solid State Relay

Maintenance free relays for load currents of up to 25 A. Positive or negative signal and high capacitive and inductive currents.

Pulse Relay

Switch consumers of up to 20 A on for a predefined time. Potential free/VCC output and positive or negative control.

Time Relays

Switch consumers of up to 70 A on or off after a predefined time. Potential free/VCC output and positive or negative control.

Toggle Relays

Switch consumers of up to 20 A on and off with a single push button. Potential free/VCC output and positive or negative control.

Voltage Monitors

Switch consumers of up to 15 A when the voltage exceeds or falls below a predefined threshold voltage.

Frequency Monitors

Switch consumers of up to 15 A on or off when a predefined frequency threshold is exceeded or not reached.

Flashers

For directional and warning flashing light applications. A blink frequency of up to 120 pulses per minute is supported.



Make any relay **watertight** with our **sockets**

Smart and parameterizable relays



IP rating up to IP6K8

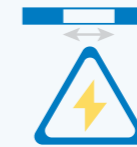

Operating voltage 9-32 V

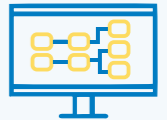

Parameterizable with MRS Realizer

MRS Realizer

MRS Realizer is the programming tool for MRS products without CAN interface, such as our Relays, M1, M3, Micro PLC and our proportional amplifier.

Programming the controllers is easy and fast because it is done via the relay contacts. You just plug in the module into the included programming station and that's it! No need to open the housing. MRS Realizer also makes it easy to organize and manage your projects and requesting pre-programmed controllers so you don't have to worry about programming at all.

In addition to the pre-built programs which you parameterize you can easily create your own programs via the Z-Graph feature.

For more information about this product, please contact our MRS customer service.



Programming Tools

MRS Applics Studio

The MRS Applics Studio is the latest development environment from MRS Electronic. With this tool, you can create software for MRS controllers. It simplifies the programming of controllers that work with CAN, LIN or input and output signals (I/O).

Simple creation

of control logic by linking several function blocks.

Integrated library

cover the standard functions for you.

Improved overview

by using different diagram pages.

Own graphic blocks

can be created with C code and managed in own graphical libraries.

Intuitive warning bar

by using different diagram pages.

Combined modules

can be created with C code and managed in own graphical libraries.

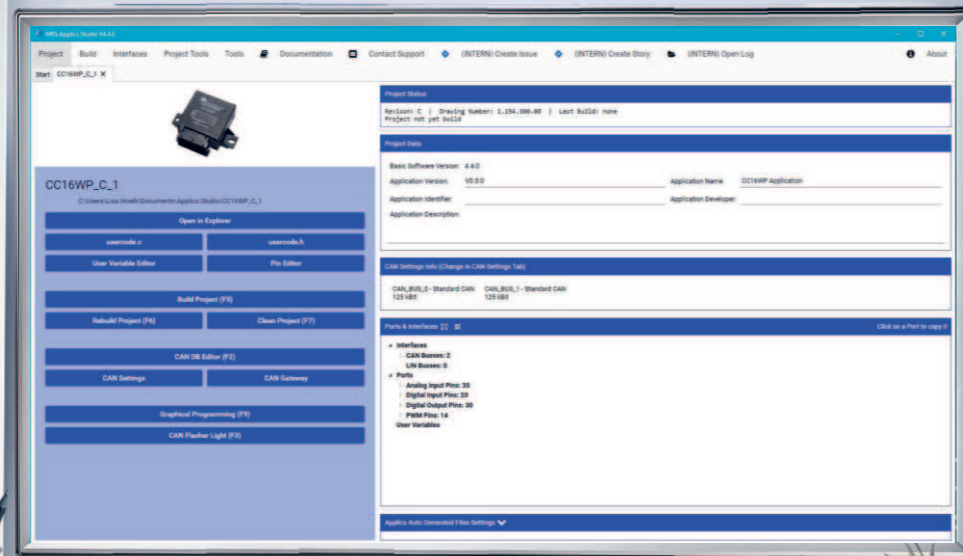

With the MRS Applics Studio, functions of the predecessor MRS Developers Studio have been improved. The in-house developed graphical programming environment and the improved programming possibilities allow you to program your applications with CAN, LIN or I/O processes even easier.

- ✓ Independent, self-developed graphical programming environment
- ✓ Dropdown menu for inputs, outputs and data points
- ✓ Importing/exporting SYM and DBC files
- ✓ Graphical libraries can be created and exported
- ✓ Easier integration into external programs like IDEs
- ✓ New User API

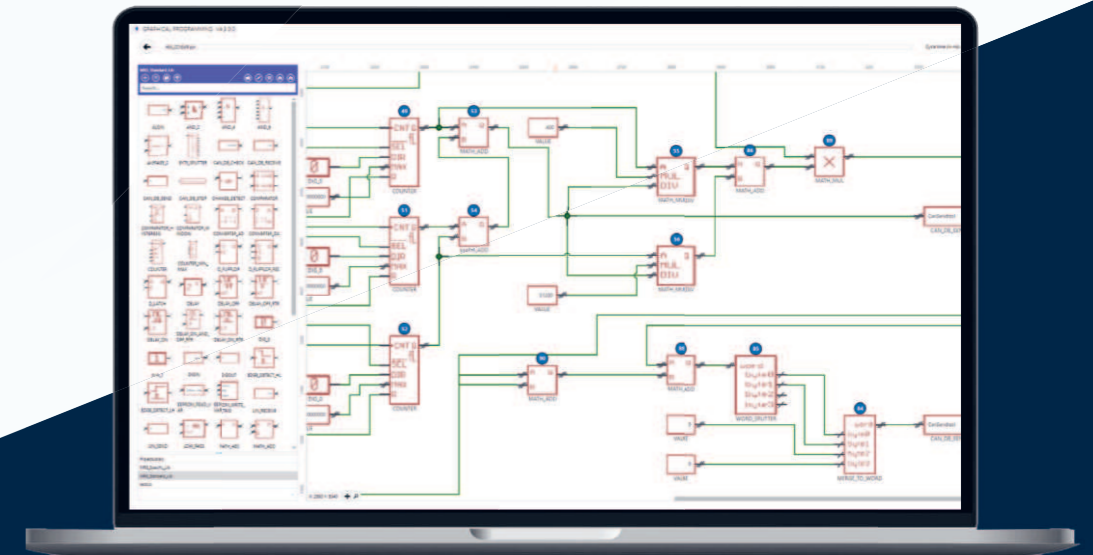

MRS Developers Studio

The MRS Developers Studio was developed for the programming of our CAN products. Programming is carried out graphically, or in the case of complex applications, in „C code“ via the easy-to-use user interface. All CAN products have a CAN bootloader that is permanently active on the modules. A new program can be flashed at any time during operation via the bootloader.

The graphical programming is similar to the FUP (function diagram) according to IEC61131. For that reason, no extensive programming knowledge is required.



Development Competencies



Project Management

- ◆ Project organization
- ◆ One contact person responsible for development projects
- ◆ Controls the project with specialist departments and production

Hardware

- ◆ Circuit diagram development
- ◆ Component selection
- ◆ Component placement
- ◆ Layout design and DFM/DFA
- ◆ Simulation
- ◆ Prototyping and testing



Software

- ◆ Bootloader
- ◆ Basic software
- ◆ Application software development for Graphical Programming tools (IEC 61131-3) – Applies Studio and HMI-application development
- ◆ PC service/diagnostics tools on Windows in addition to MRS-Products: Configuration or parameter tools
- ◆ AUTOSAR Classic application development

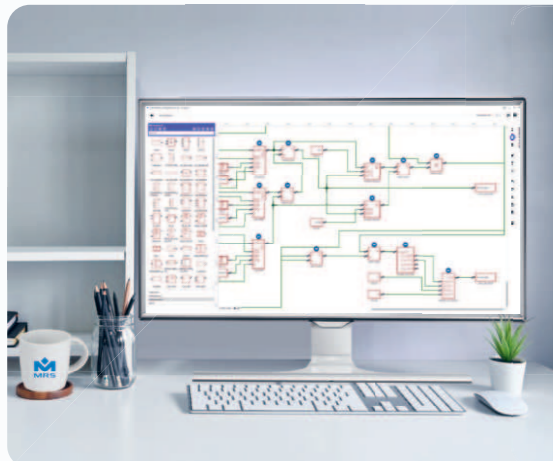

Mechanics

- ◆ Individual housing development
- ◆ Inhouse prototype construction with e.g. CNC milling machine and 3D printing (FDM)

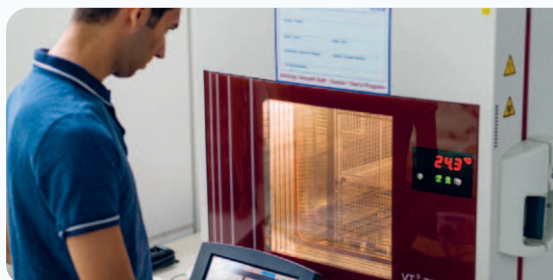

Product Validation

- ◆ Internal test laboratory
- ◆ Environmental tests
- ◆ EMC/EMC tests
- ◆ Handling of CE certification

Production at our Headquarters

With our modern production facilities, we produce hardware for our standard and customized electronics. Each product is tested at least four times during the production process.

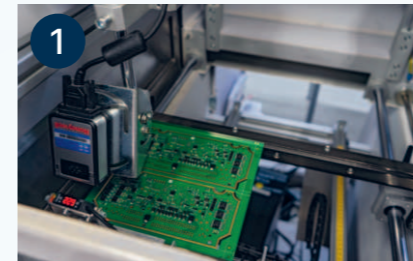

Label station

For us, first-class traceability starts with component procurement. In production, this is continued via a label



SMD

- ◆ Solder paste printing
- ◆ SPI → Checking paste printing results
- ◆ Placing components
- ◆ Soldering in reflow-oven



AOI

Optical inspection of components and soldering results

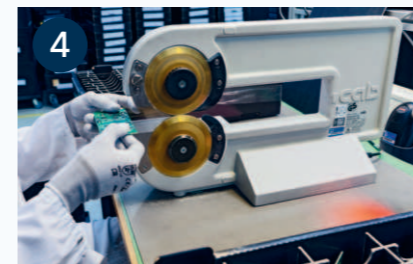

Depaneling

Cutting or milling the PCBs



Manual assembly

Attaching connectors, relays, displays, etc.

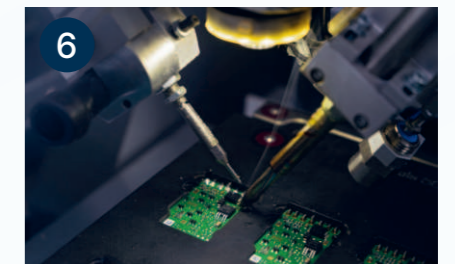

Soldering

- ◆ Wave soldering
- ◆ Selective soldering
- ◆ Soldering robot



Potting / Painting

- ◆ Protection against moisture, corrosion and dust
- ◆ Mechanical protection, improved thermal resilience and electrical insulation



ICT / EOL

- ◆ Electrical function test of the modules
- ◆ Parameterize
- ◆ Flashing



Printing

- ◆ Pad printing process or stickering
- ◆ Custom printing or MRS standard

Markets



Automotive

We are IATF-16949 certified and meet all major automotive standards. This allows you to use our controllers, relays and gateways directly without input testing procedures and save valuable time.



Agriculture

Whether for stationary or mobile use - our ISOBUS-capable controllers and compact MRS modules enable precise and robust control mechanisms in your field applications.



Commercial

Realize completely individual functions in your commercial vehicles with our MRS modules. Optimize data evaluation and transmission for reliable sensor-actuator communication with our gateways.



Construction

Our compact and durable controllers, relays and gateways are perfect for use in your construction vehicles and equipment. Even in extreme vibration and environmental conditions.



Special Vehicles

The flexible use of our MRS controllers and gateways enables you to implement a wide variety of control and monitoring functions in your special vehicles. Among others in the field of hydraulic and engine control.



Marine

Optimize your fleet management and monitoring with our intelligent electronic marine products. This will reduce costs and increase the reliability of your ship or fleet.

Applications Hydraulic Control

Control electro-hydraulic movements of your vehicles, such as construction equipment, agricultural or municipal vehicles, using our compact and waterproof MRS modules.

Control of various types of hydraulic valves



Directional valves

Our MRS-solution is used to control directional valves for changing the direction of the hydraulic fluid. For example, you can enable cylinder extension and retraction or change the direction of rotation on a hydraulic motor.



Pressure relief valves

Use the MRS-modules to dynamically set the required pressure of the hydraulic system, e.g., by means of a proportionally controlled pressure relief valve, and thus protect the hydraulic circuit from overloads.



Flow control valves

You can also use the MRS-modules to control flow valves, i.e., to control the flow rate in order to adjust the speed of movement of cylinders and motors.

Applications for mobile machines



Agricultural vehicles

Control hydraulic functionalities of your attachments such as a round baler, a mower, a loader wagon and many more.

Construction machinery

Control a wide range of applications in your wheel loader or excavator with the help of MRS modules.



Municipal vehicles

Quickly and easily control the functions of various attachments, such as the mower, the casting arm or the front-mounted sweeper.



The Austrian family-owned company PÖTTINGER is a specialist for grassland, soil cultivation and seeding technology in the field of agricultural technology. With our hydraulic solutions, we facilitate functions in PÖTTINGER loader wagons and provide hydraulic control for mowers and round balers.



Round baler

Hydraulic control of the tailgate and the wrapping and tipping process.



Loader wagon

Control of the hydraulic cutterbar swivel.



Cutterbar

Hydraulic control of mower units.

Lighting Control

Whether switching the lighting on and off, monitoring the load current, detecting a defective light source or after glowing the light source for a predefined period of time - MRS offers a complete product portfolio of controllers, connected controllers and relays for controlling light sources in vehicles and mobile machinery.

Control of vehicle lighting



Direct lighting control according to user input

With our modules, you can control the lighting of vehicle interiors (Ambiance/ Mood Lighting) or activate interval-switched applications such as turn signals or hazard lights. The controls and relays receive the driver's information via device input, usually a switch, knob or operating display, and forward the commands on to the respective light sources.

Indirect lighting control after engine start

Our control systems enable you, among other things, to automatically activate the work environment lighting of construction machinery when the engine is turned on (daytime running lights) or to switch on the revolving lights of special vehicles such as sweepers or snow groomers without operator intervention. The modules activate the lights when a defined action such as engine activation occurs.



Monitoring, detection and warning of broken lights

Monitor the load current with our MRS-controllers. If this decreases or fails, this is detected by the controller and an indication or warning message is sent that this light is broken and has failed.

DC Motor Control

To control direct current (DC) motors in vehicles and mobile machines, we offer you the perfect solutions. The main applications include acceleration and braking processes of the motor or the variation of the direction of rotation. In addition, the motor current can be monitored and thus the motor can be switched off or reversed at a previously defined threshold. For this purpose, MRS offers various motor controllers with different current consumptions.

Application areas of motor controls



Control of lifting systems

Use our motor controller to control lifting systems in your special vehicles, such as the ambulance stretcher or the coffin lift function in a hearse.

Control of the temperature regulation of hydraulic oil coolers

With the motor controllers, you can control the automatic temperature regulation of electrically operated hydraulic oil coolers by increasing or decreasing the fan speed so that the oil temperature remains below a defined value.



Realization of comfort functions

Control various comfort functions such as automatic seat adjustment of the backrest or footrest, electrically adjustable side mirrors, opening and closing of doors or trunk lids, or operating the blinds.

Sensor Processing

For the processing of sensor data we offer a complete product portfolio of controllers and gateways. In addition to reading and logging data, these can be converted and forwarded with controllers and gateways into a current, CAN- or LIN-bus message. In interaction with a controller, programmed actions are executed if required.

Processing of various sensor data



Detection of objects

Use the MRS-products in the area of object detection and process the information from ultrasonic sensors, inductive and magnetic proximity switches, capacitive sensors or mechanical precision switches.

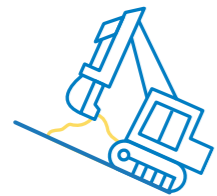

Angular position control

Let your vehicles use MRS-controllers to evaluate and process data from inclination sensors. In this way, log and control the angular position of mobile machines such as the alignment of an elevating work platform.



Processing distance information

Process distance information from ultrasonic distance sensors, inductive distance sensors or radar sensors, e.g., in the area of ground distance control or during material-friendly opening and closing of hydraulic rear walls.



Monitoring of process values

Monitor the measured process values of your vehicle sensors such as temperature, pressure, level, or flow. Based on this, you can have required actions processed automatically.



Measuring forces and strains

Measure forces and strains on your mobile working machine and prevent operating errors or damage, such as cranes tipping over or drive train overloads.



Evaluation of ambient data

Let the vehicle sensor evaluate and process the surrounding data. For example, the MRS-products receive information from the rain sensor about rain intensity and automatically control the windshield wiper depending on this.

Rosenbauer is the world's leading manufacturer of firefighting technology for fire protection and civil protection management, such as fire engines and firefighting equipment of all kinds. MRS facilitates various applications in the PANTHER, which is one of the most successful, efficient and variable airport fire fighting vehicles worldwide.



Extinguishing agent display

A message is sent to the MRS controller via a CAN message indicating what percentage of the tank is full. This message is converted and displayed in predefined bar units in the form of an LED display in the vehicle.



RLS evaluation

The rain/light sensor tells the vehicle whether it is currently raining and there is water on the windshield. The MRS control system evaluates this information and the PANTHER's windshield wiper is automatically activated in wet conditions.

Trailer Control

We have already developed various modules that ensure the function of the trailer lighting as well as the retractable trailer coupling smoothly and safely. Our modules are freely programmable and reliable. Whether your system is analog or uses CAN-Bus, we have a module that supports both functions.

Control your trailer lighting and trailer hitch functions



Analog trailer module

Controls your trailer lights and supports a variety of programming options.

CAN trailer module

Smart control of trailer lights via CAN-Bus with free programmability for individual functionalities.



Retractable trailer hitch control module

Controls retractable towbar folding functions and ensures safe user experience.

Your advantages of our solution



Robust products "made in Germany"

Modern manufacturing technologies as well as international certifications for products and manufacturing - we create high-quality and long-lasting solutions.



Flexible functionality

The space-saving robust products offer you high flexibility. They are easy to program and highly customizable for your requirements.



Full safety compliance

All our retractable trailer hitch modules are ISO 26262 compliant and are ASIL A or B rated, depending on the system. All modules are tested to ECE R10 and can therefore be used in on-road vehicles without further testing.

Emission Monitoring

Our diesel exhaust emissions monitoring system is a complete, stand-alone solution for diesel engine retrofit and compliance with emissions and environmental regulations. It is designed to monitor the diesel particle filter of your on/off-road vehicles and boats by continuously measuring, displaying and logging NOx levels, exhaust gas temperature, counter-pressure (DPF) and engine speed. If necessary, you can initiate appropriate countermeasures to reduce NOx gases and thus reduce CO2 emissions.

Monitor your emissions

Emission monitoring evaluates the emission values received from the sensors and compare them with preconfigured settings. If there is a deviation in these values, user intervention in the form of maintenance or service is required. The system alerts the user with a visual and acoustic alarm and stores the incident.

Application areas of the emission monitoring system



Marine

With our emission monitoring solution, you can retrofit old diesel engines of boats and ships such as tourist boats, yachts, commercial ships or cargo ships. Emission levels become measurable and can be tracked, monitored and showed in a cloud web application.

Mining

In the mining sector, especially in underground mining, it is particularly important to monitor the air pollution generated by the various mining machines. Our MRS solution can be used in a wide variety of machines to monitor engine and DPF filter levels. Among others, our solution has already been used in underground mining in Australia since 2014.



Construction industry

Our solution is also particularly well suited for retrofitting the legally required DPF monitoring in the construction machinery sector. Use our products in a wide variety of mobile work machines and record the exhaust gas values of your diesel engines.

MRS Worldwide

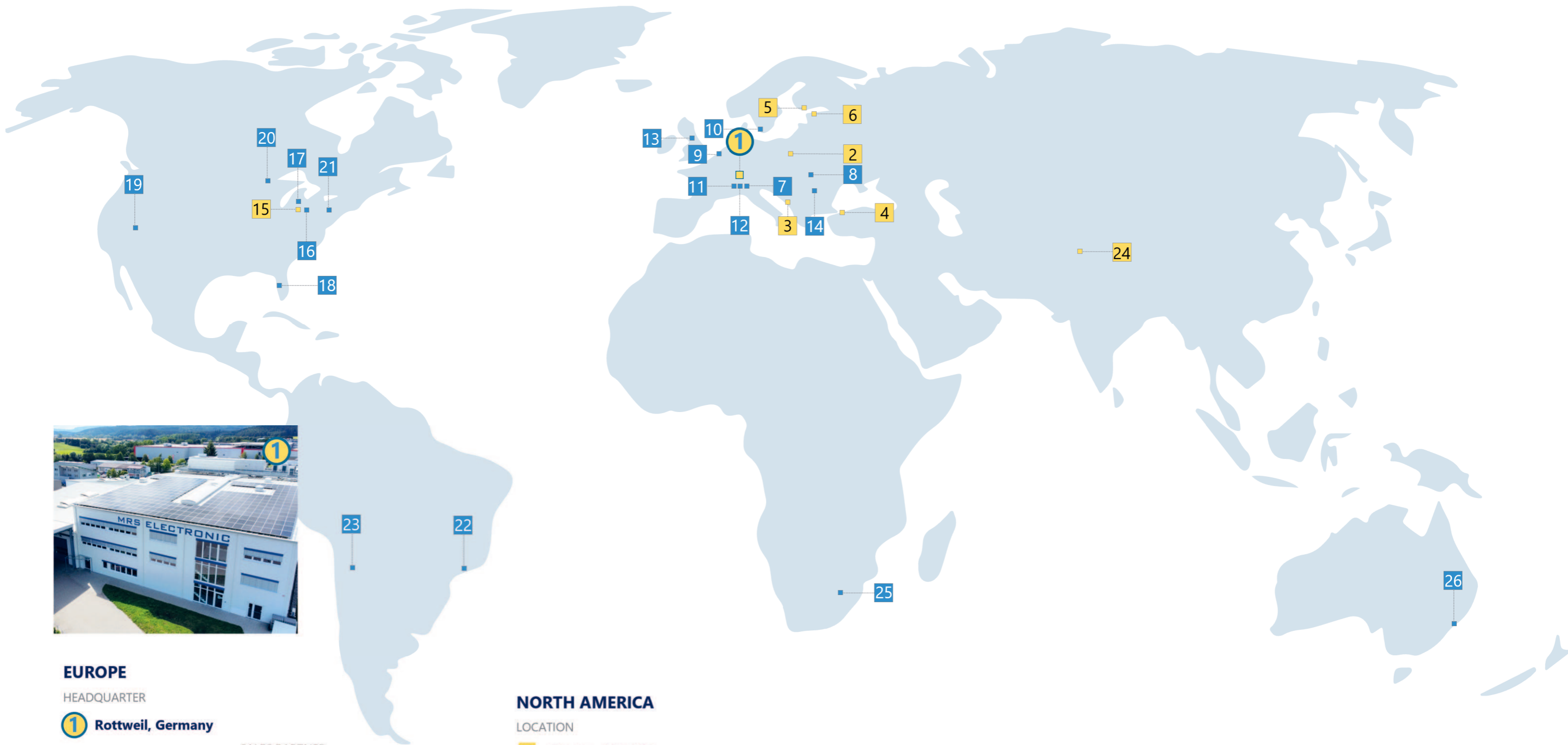

EUROPE

HEADQUARTER

1 Rottweil, Germany

LOCATIONS

- 2** Krakow, Poland
- 3** Split, Croatia
- 4** Istanbul, Türkiye

SALES REPRESENTATIVE

- 5** Espoo, Finland
- 6** Riga, Latvia

SALES PARTNER

- 7** Tritecnica, Italy
- 8** Imcon Electronics, Czech Republic
- 9** Epec, Netherlands
- 10** HydX, Sweden
- 11** Höger Tech, Switzerland
- 12** HOELZLE Fahrzeugelektrik, Switzerland
- 13** Distec LTD, Great Britain
- 14** Lájer & V. Kereskedelm, Hungary

NORTH AMERICA

LOCATION

15 Dayton, OH, USA

SALES PARTNER

- 16** OPS Control, OH, USA
- 17** Hughes-Peters, OH, USA
- 18** Wesgarde, FL, USA
- 19** Protronix Controls, UT, USA
- 20** Nott Company, MN, USA
- 21** Beiler Hydraulics, PA, USA

SOUTH AMERICA

SALES PARTNER

- 22** Supportronics, Brazil
- 23** Supportronics, Argentina

ASIA

LOCATION

24 Islamabad, Pakistan

AFRIKA

SALES PARTNER

25 Klare Tech, South Africa

AUSTRALIA

SALES PARTNER

26 kin8tic, Australia

Get more information now at
mrs-electronic.com

About MRS

Your Vision. Our Technology.

For more than 25 years, MRS Electronic has been developing and producing innovative electronic products and customer-specific hardware and software solutions at its Headquarters in Rottweil in Germany. With numerous international locations, MRS supplies customers worldwide.

With a young and committed team of over 350 employees worldwide, new ideas for innovative products are created every day and individual customer projects are implemented. The majority of our teams focus on development topics.

MRS Electronic GmbH & Co. KG

Klaus-Gutsch-Str. 7
78628 Rottweil, Germany

www.mrs-electronic.com
info@mrs-electronic.com